

EDD

NOTES:  
UNLESS OTHERWISE SPECIFIED, TOLERANCES ARE  $\pm .010$ " [.254mm].

CAD#81-3001BF

DRAWING NO.:

81-3001B-\*

REV.

F

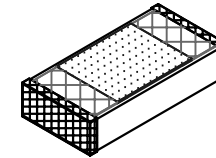
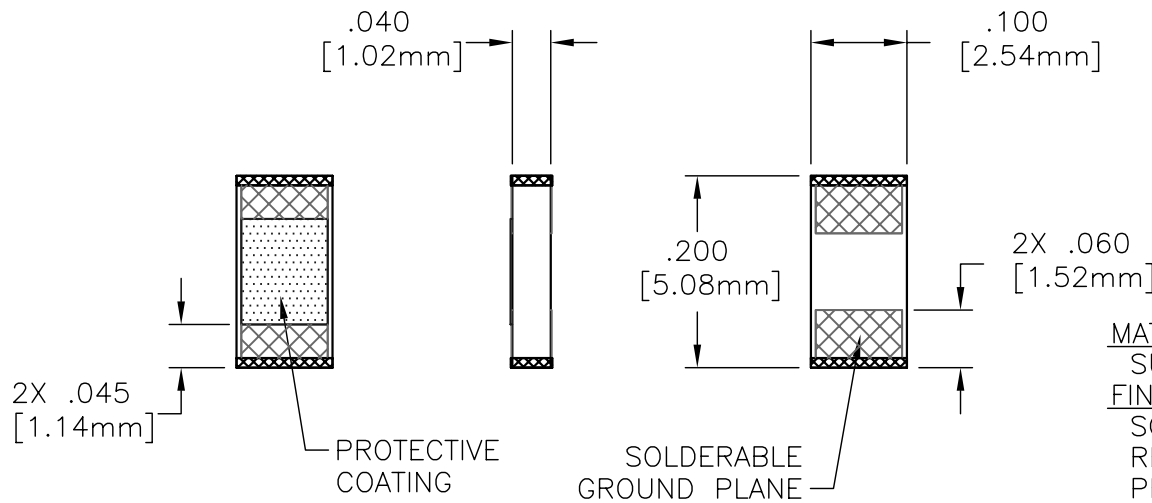

MATERIALS:

SUBSTRATE: BERYLLIUM OXIDE

FINISH:

SOLDERABLE TERMINALS: PLATED TIN/LEAD

RESISTIVE FILM: NICHROME

PROTECTIVE COATING: POLYMER

TECHNICAL:

FREQUENCY RANGE (GHz): DC-4.0

TEMPERATURE COEFFICIENT:  $\pm 200$  PPM/ $^{\circ}$ C MAX

OPERATING TEMPERATURE ( $^{\circ}$ C):  $-55^{\circ}$  TO  $+150^{\circ}$

AVERAGE POWER (WATTS): 5

\*DC RESISTANCE: 2.5-200 OHMS

				ECN# N/A	APVD	DATE	REFERENCE	 8851 OLD KANSAS AVE. STUART, FL. 34997 772-286-9300					
				UNLESS OTHERWISE SPECIFIED			CATALOG	TITLE <b>CHIP, RESISTOR, 5 WATT</b>					
F	ECN#01427	BLP 06/23/02		1. DO NOT SCALE DRAWING 2. DIMENSIONS ARE IN INCHES 3. DIMENSIONS ARE AFTER PLATING 4. CORNERS, EDGES AND FILLETS: R 5. SURFACE ROUGHNESS: 6. REMOVE ALL BURRS			MATERIAL			-			
E	ECN# N/A	-	-				TOLERANCES			FINISH	-		
D	ECN# N/A	-	-				.X $\pm$ .XX $\pm$ .XXX $\pm$			SCALE CAGE CODE ID NO. SIZE DRAWING NO.: REV. <b>5/1 2Y194 A 81-3001B-* F</b>			
C	ECN# N/A	-	-				ANGLES X' $\pm$					MFG: -	CHKD.: -
B	ECN# N/A	-	-	THE INFORMATION CONTAINED HEREIN IS: (A) CONSIDERED PROPRIETARY TO FLORIDA RF LABS INC.; (B) PROTECTED BY COPYRIGHT OWNED BY FLORIDA RF LABS INC.; (C) CONSIDERED A "WORK FOR HIRE" UNDER COPYRIGHT LAW; (D) PROTECTED BY TRADE SECRET LAWS WHICH MAKE ILLEGAL THE MISAPPROPRIATION OF THIS INFORMATION; AND (E) IS TO BE USED SOLELY FOR THE PURPOSE WHICH IT IS SUPPLIED. THIS INFORMATION SHALL NOT BE DISCLOSED IN WHOLE OR IN PART, TO ANY PARTY, FOR ANY REASON WITHOUT THE EXPRESS WRITTEN CONSENT OF A QUALIFIED EXECUTIVE OF FLORIDA RF LABS INC.			DRAWING NO.:		REV.				
A	ECN# N/A	-	-				DRAWN: BLP 06/23/02		SHEET	OF			