

# EDD

NOTES:  
UNLESS OTHERWISE SPECIFIED, TOLERANCES ARE  $\pm .010"$  [.254mm].

CAD#81-3028A

DRAWING NO.:

81-3028-\*

REV.

A

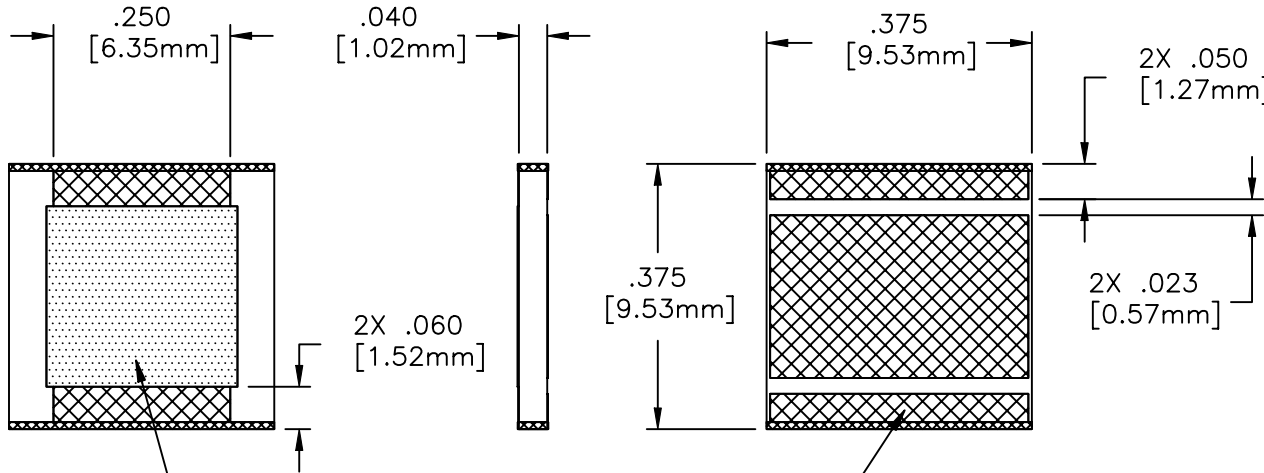

PROTECTIVE COATING

SOLDERABLE GROUND PLANE

**MATERIALS:**

SUBSTRATE: BERYLLIUM OXIDE

**FINISH:**

SOLDERABLE TERMINALS: PLATED TIN/LEAD

RESISTIVE FILM: NICHROME

PROTECTIVE COATING: 240SB-HSP BLUE

				ECN# N/A	APVD -	DATE -	REFERENCE -	 8851 OLD KANSAS AVE. STUART, FL. 34997 561-286-9300			
				UNLESS OTHERWISE SPECIFIED 1. DO NOT SCALE DRAWING 2. DIMENSIONS ARE IN INCHES 3. DIMENSIONS ARE AFTER PLATING 4. CORNERS, EDGES AND FILLETS: R MAX 5. SURFACE ROUGHNESS: 6. REMOVE ALL BURRS			MATERIAL -	TITLE <b>CHIP, RESISTOR, 250 WATT</b>			
				TOLERANCES .X $\pm$ .XX $\pm$ .XXX $\pm$ ANGLES X' $\pm$			FINISH -				
				THE INFORMATION CONTAINED HEREIN IS: (A) CONSIDERED PROPRIETARY TO FLORIDA RF LABS INC.; (B) PROTECTED BY COPYRIGHT OWNED BY FLORIDA RF LABS INC.; (C) CONSIDERED A "WORK FOR HIRE" UNDER COPYRIGHT LAW; (D) PROTECTED BY TRADE SECRET LAWS WHICH MAKE ILLEGAL THE MISAPPROPRIATION OF THIS INFORMATION; AND (E) IS TO BE USED SOLELY FOR THE PURPOSE WHICH IT IS SUPPLIED. THIS INFORMATION SHALL NOT BE DISCLOSED IN WHOLE OR IN PART, TO ANY PARTY, FOR ANY REASON WITHOUT THE EXPRESS WRITTEN CONSENT OF A QUALIFIED EXECUTIVE OF FLORIDA RF LABS INC.			SCALE 4/1	CAGE CODE ID NO. 2Y194	SIZE A	DRAWING NO.: 81-3028-*	REV. A
REV.	DESCRIPTION	DRAWN	APVD.				MFG:	CHKD.:	DRAWN: BLP 11/27/01	SHEET 1 OF 2	

# EDD

CAD#81-3028A		DRAWING NO. <b>81-3028-*</b>	REV <b>A</b>		
REQUIREMENTS	RATING	REQUIREMENTS	RATING		
FREQUENCY RANGE (GHz)	DC-1.0	VIBRATION	MIL-STD-202 METHOD 204 COND. D (20 G's)		
TEMPERATURE COEFFICIENT	LESS THAN 200 PPM				
OPERATING TEMPERATURE (°C)	-55° TO +150°	SHOCK	MIL-STD-202 METHOD 213 COND. I (100 G's)		
AVERAGE POWER (WATTS)	250				
*DC RESISTANCE	5-200 OHMS	THERMAL SHOCK	MIL-STD-202 METHOD 107 COND. B (-65 TO +125 °C)		
		TERMINAL STRENGTH	MIL-STD-202 METHOD 211 COND. A		
		MOISTURE RESISTANCE	MIL-STD-202 METHOD 106 LESS STEP 7B		
<p style="text-align: center;">AVERAGE POWER DERATING</p>		SOLDERABILITY	MIL-STD-202 METHOD 208		
		RESISTANCE TO SOLDER HEAT	MIL-STD-202 METHOD 210		
TITLE <b>CHIP, RESISTOR, 250 WATT</b>		8851 OLD KANSAS AVE. STUART, FL. 34997 561-286-9300	DRAWN <b>-</b> SHEET 2 OF 2	DRAWING NO. <b>81-3028-*</b>	REV <b>A</b>