

EDD

NOTES:
UNLESS OTHERWISE SPECIFIED, TOLERANCES ARE $\pm .010"$ [.254mm].

CAD#81-3076TC

DRAWING NO.:
81-3076TC-*

REV.
N/C

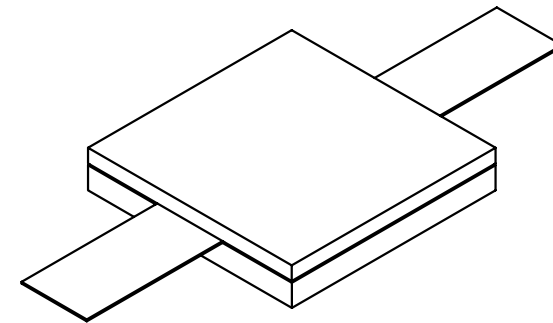
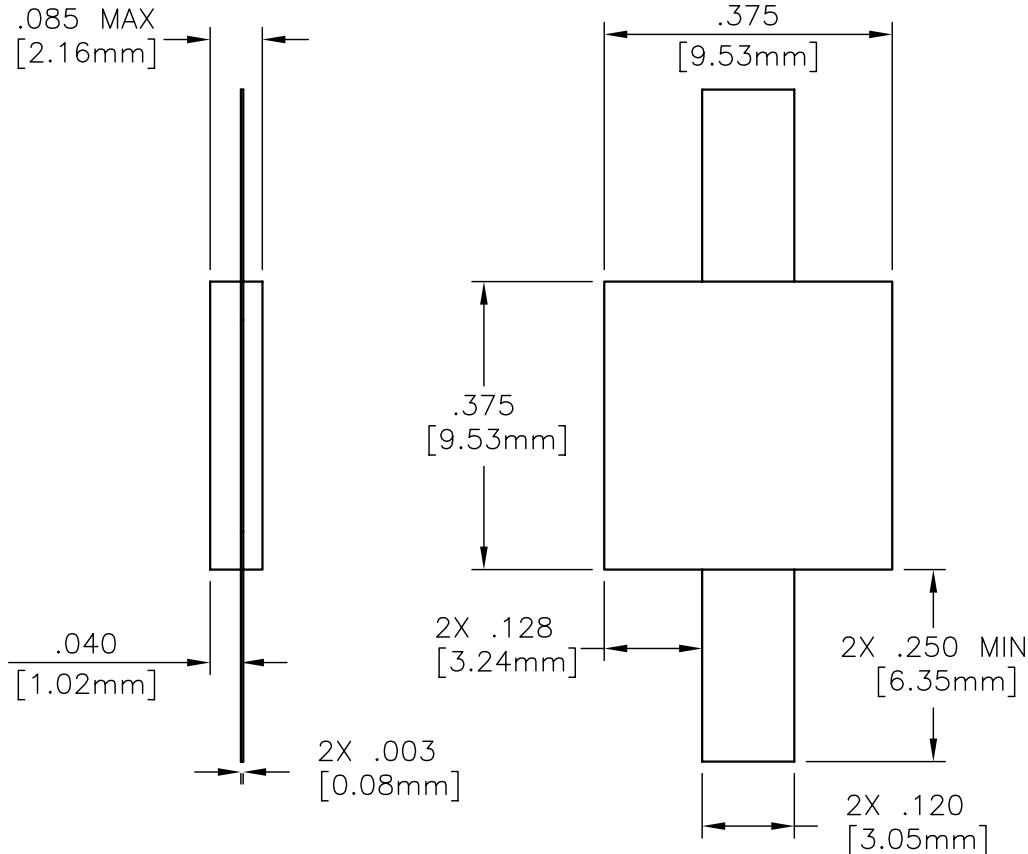

MATERIAL:

SUBSTRATE: BERYLLIUM OXIDE
COVER: ALUMINA
TAB: BERYLLIUM COPPER PER ASTM B194
RESISTIVE FILM: NICHROME

FINISH:

SOLDERABLE GROUND PLANE: TIN/LEAD OVER NICKEL
TAB: TIN/LEAD PER MIL-T-10727

ELECTRICAL:

*DC RESISTANCE: 10-350 OHMS
FREQUENCY RANGE: DC-1.0 GHz
AVERAGE POWER: 250 WATTS
CAPACITANCE: 1.00 pF
TEMPERATURE COEFFICIENT: ± 200 PPM/ $^{\circ}$ C MAX
OPERATING TEMPERATURE: -55° TO $+150^{\circ}$ C

				EN# 04-F0164	APVD -	DATE -	REFERENCE		 8851 OLD KANSAS AVE. STUART, FL. 34997 772-286-9300			
				UNLESS OTHERWISE SPECIFIED			CATALOG		TITLE TAB & COVER, RESISTOR, 250 WATT			
				1. DO NOT SCALE DRAWING 2. DIMENSIONS ARE IN INCHES 3. DIMENSIONS ARE AFTER PLATING 4. CORNERS, EDGES AND FILLETS: R MAX 5. SURFACE ROUGHNESS 6. REMOVE ALL BURRS			MATERIAL -					
				TOLERANCES			FINISH -					
				.X \pm	ANGLES X $^{\circ}$ \pm		SCALE		CAGE CODE ID NO.	SIZE	DRAWING NO.:	REV.
				.XX \pm			4/1		2Y194	A	81-3076TC-*	N/C
				.XXX \pm			MFG:		CHKD.: DR 07/09/04	DRAWN: AWM 05/04/04	SHEET	OF
THE INFORMATION CONTAINED HEREIN IS: (A) CONSIDERED PROPRIETARY TO FLORIDA RF LABS INC.; (B) PROTECTED BY COPYRIGHT OWNED BY FLORIDA RF LABS INC.; (C) CONSIDERED A "WORK FOR HIRE" UNDER COPYRIGHT LAW; (D) PROTECTED BY TRADE SECRET LAWS WHICH MAKE ILLEGAL THE MISAPPROPRIATION OF THIS INFORMATION; AND (E) IS TO BE USED SOLELY FOR THE PURPOSE WHICH IT IS SUPPLIED. THIS INFORMATION SHALL NOT BE DISCLOSED IN WHOLE OR IN PART, TO ANY PARTY, FOR ANY REASON WITHOUT THE EXPRESS WRITTEN CONSENT OF A QUALIFIED EXECUTIVE OF FLORIDA RF LABS INC.												