

TITLE: ENGINEERING CONTROL DRAWING.

PART IDENTIFIER: HDD2F REV -

DESCRIPTION: HYBRID COUPLER ROHS COMPLIANT

ASSEMBLY DWG: HDD2F

1.0 SPECIFICATIONS:

1.1 ELECTRICAL:

- 1.1.1 CHARACTERISTIC IMPEDANCE: 50 OHMS NOMINAL.
- 1.1.2 FREQUENCY: 811 MHz TO 1000 MHz
- 1.1.3 INSERTION LOSS: 0.15 dB MAX
- 1.1.4 VSWR: 1.15 MAX
- 1.1.5 AMPLITUDE BALANCE: ±0.3 dB MAX
- 1.1.6 PHASE BALANCE: ±2°
- 1.1.7 ISOLATION: 26 dB MIN.
- 1.1.8 POWER RATING: 200 WATTS MINIMUM.
- 1.1.9 PHASE TABLE

PORTS	J1	J2	J3	J4
J1	-	ISO	-90°	0°
J2	ISO	-	0°	-90°
J3	-90°	0°	-	ISO
J4	0°	-90°	ISO	-

1.2 MECHANICAL:

- 1.2.1 OUTLINE DWG: SEE SHEET 2,
- 1.2.2 WORKMANSHIP: PER MIL-HDBK0454 GUIDLINE 9.

1.3 ENVIRONMENTAL:

- 1.3.1 OPERATING TEMPERATURE RANGE: 55°C TO +85°C.
- 1.3.2 NON-OPERATING TEMPERATURE RANGE: N/A

2.0 UNIT MARKING: HYBRIX AND HDD2F.
LEGIBILITY AND PERMANENCY PER MIL-STD-130.

3.0 QUALITY ASSURANCE:

3.1 SAMPLE INSPECT PER MIL-STD-105, LEVEL II, 1.0% AQL.

- 3.1.1 VISUAL AND MECHANICAL EXAMINATION FOR CONFORMANCE TO OUTLINE DRAWING REQUIREMENTS.
- 3.1.2 MEASURE AMPLITUDE RESPONSE.
 - 3.1.2.1 ACCEPTANCE LIMITS: PER 1.1.4, 1.1.5 AND 1.1.7.

3.2 TEST DATA REQUIREMENTS:

- 3.2.1 NO TEST DATA REQUIRED FOR CUSTOMER.
- 3.2.2 DATA RETENTION - 12 MONTHS

4.0 PACKAGING: PER MC0023, MARK CONTAINER(S) WITH THE FOLLOWING:
CUSTOMER P/N, REVISION LEVEL
VENDOR CODE (24602)
LOT AND DATE CODES.

FLORIDA RF LABS 8851 SW OLD KANSAS AVE. STUART, FL 34997	CAGE CODE # 2Y194		DWG #	HDD2F
	CHANGE NOTICE	EN 07-F0492	REV LVL	A
			SHEET	1 OF 2

TOP SIDE

BOTTOM SIDE

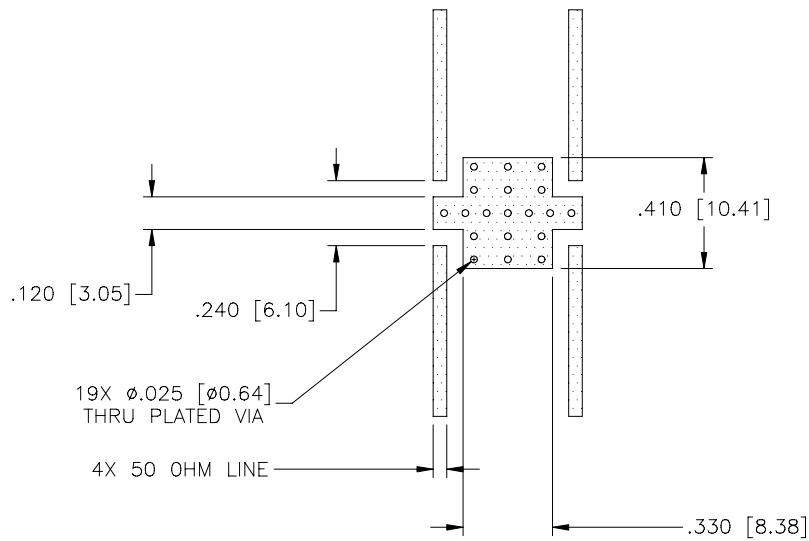
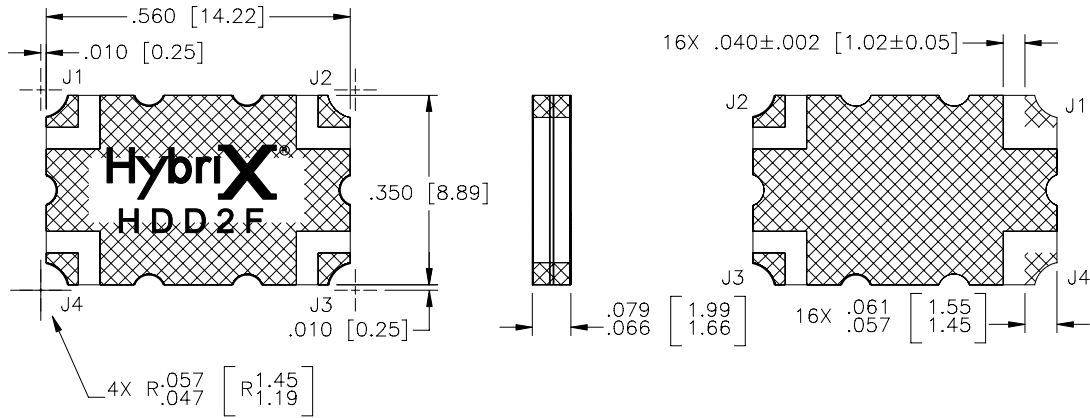

SUGGESTED BOARD MOUNTING

 8851 SW OLD KANSAS AVE STUART, FL 34997 PHONE NO. (772)286-9300 FAX NO. (772)283-5286	UNLESS OTHERWISE SPECIFIED DIMENSIONS ARE IN INCHES TOLERANCES FRACT ±1/16 ANG ±5° XX ±0.01 XXX ±0.010 XXXX ±0.0005		THESE DRAWINGS AND SPECIFICATIONS ARE THE PROPERTY OF EMC TECHNOLOGY INC AND SHALL NOT BE DUPLICATED OR USED AS BASIS FOR THE MANUFACTURE OR SALE OF PARTS OR DEVICES WITHOUT PERMISSION.			
	CAGE CODE	SCALE	DRAWN BY	CHECKED BY	APPROVED BY	
	2Y194	5:1	CRH 08/23/07			
	REV	CHANGE NOTICE	DRAWING NO	SHEET		
A	EN 07-F0492	HDD2F	2 OF 2			