

TITLE: ENGINEERING CONTROL DRAWING.

PART IDENTIFIER: HEAF REV A

DESCRIPTION: HYBRID COUPLER ROHS COMPLIANT

ASSEMBLY DWG: HEAF

1.0 SPECIFICATIONS:

1.1 ELECTRICAL:

- 1.1.1 CHARACTERISTIC IMPEDANCE: 50 OHMS NOMINAL.
- 1.1.2 FREQUENCY: 150 MHz TO 175 MHz
- 1.1.3 INSERTION LOSS: 0.30 dB MAX
- 1.1.4 VSWR: 1.20:1 MAX
- 1.1.5 AMPLITUDE BALANCE: ±0.25 dB MAX
- 1.1.6 PHASE BALANCE: ±2°
- 1.1.7 ISOLATION: 20 dB MIN.
- 1.1.8 POWER RATING: 200 WATTS MINIMUM.
- 1.1.9 FOR INPUT ON PORT 1:

PORTS	J1	J2	J3	J4
J1	-	ISO	-90°	0°
J2	ISO	-	0°	-90°
J3	-90°	0°	-	ISO
J4	0°	-90°	ISO	-

1.2 MECHANICAL:

- 1.2.1 OUTLINE DWG: SEE SHEET 2,
- 1.2.2 WORKMANSHIP: PER MIL-HDBK-454 GUIDLINE 9.

1.3 ENVIRONMENTAL:

- 1.3.1 OPERATING TEMPERATURE RANGE: 55°C TO +85°C.
- 1.3.2 NON-OPERATING TEMPERATURE RANGE: N/A

2.0 UNIT MARKING: FLORIDA RF LABS LOGO, HYBRIX AND HEAF.
LEGIBILITY AND PERMANENCY PER MIL-STD-130.

3.0 QUALITY ASSURANCE:

3.1 SAMPLE INSPECT PER MIL-STD-105, LEVEL II, 1.0% AQL.

- 3.1.1 VISUAL AND MECHANICAL EXAMINATION FOR CONFORMANCE TO OUTLINE DRAWING REQUIREMENTS.
- 3.1.2 MEASURE AMPLITUDE RESPONSE.
 - 3.1.2.1 ACCEPTANCE LIMITS: PER 1.1.4, 1.1.5 AND 1.1.7.

3.2 TEST DATA REQUIREMENTS:

- 3.2.1 NO TEST DATA REQUIRED FOR CUSTOMER.
- 3.2.2 DATA RETENTION - 12 MONTHS

4.0 PACKAGING: PER 751W153, MARK CONTAINER(S) WITH THE FOLLOWING:
CUSTOMER P/N, REVISION LEVEL
VENDOR CODE (2Y194)
LOT AND DATE CODES.

FLORIDA RF LABS 8851 SW OLD KANSAS AVE. STUART, FL 34997	CAGE CODE # 2Y194		DWG #	HEAF
	CHANGE NOTICE	08-F0533	REV LVL	A
			SHEET	1 OF 2

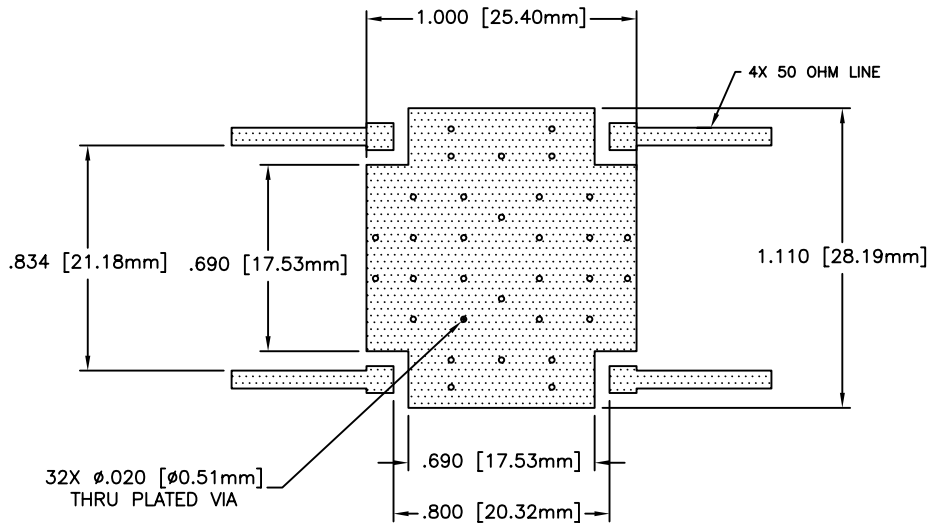
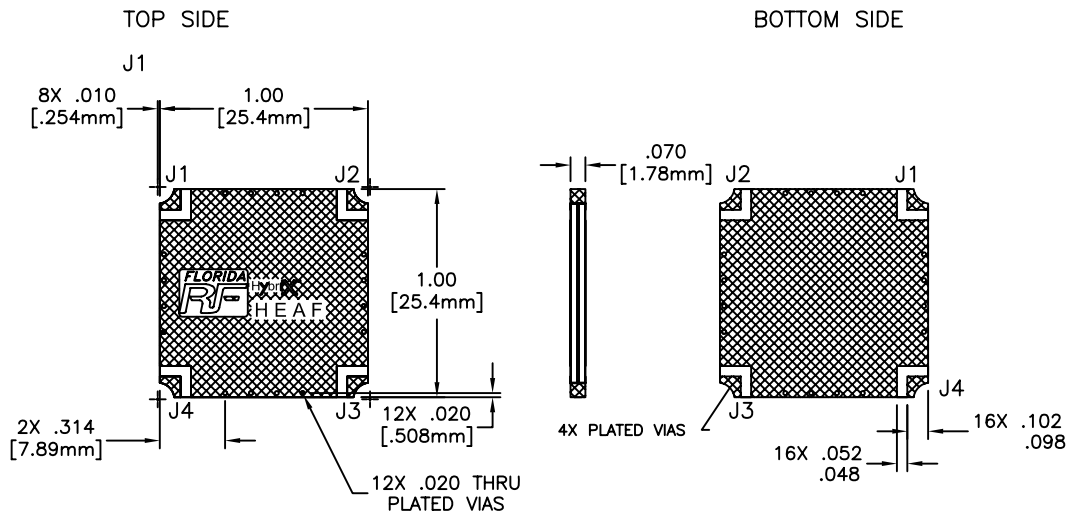

SUGGESTED BOARD MOUNTING

 8851 SW OLD KANSAS AVE STUART, FL 34997 PHONE NO. (772)286-9300 FAX NO. (772)283-5286	UNLESS OTHERWISE SPECIFIED DIMENSIONS ARE IN INCHES TOLERANCES FRACT ±1/16 ANG ±5° XX ±0.01 XXX ±0.005 XXXX ±0.0005	THESE DRAWINGS AND SPECIFICATIONS ARE THE PROPERTY OF EMC TECHNOLOGY INC AND SHALL NOT BE DUPLICATED OR USED AS BASIS FOR THE MANUFACTURE OR SALE OF PARTS OR DEVICES WITHOUT PERMISSION.				
		CAGE CODE 2Y194	SCALE 5:1	DRAWN BY OJC 06/10/08	CHECKED BY	APPROVED BY
	REV A	CHANGE NOTICE 08-F0533	DRAWING NO HEAF	SHEET 2 OF 2		