

Power (W)* Max	Transmission	Frequency Max (GHz)	VSWR (Max)	Dimensions: inches (mm)					Part Number
				L	W	H	I	Pw	
30	RF - DC	DC - 2.5 2.5 - 4.0	1.10 1.35	0.200 (5.08)	0.200 (5.08)	0.053 (1.35)	0.051 (1.30)	0.023 (0.58)	XPD

* Peak power is typically 10 times the maximum power rating with a 1% duty cycle and 100 microsecond pulse width. Please call the factory for your specific application.

Dimensions

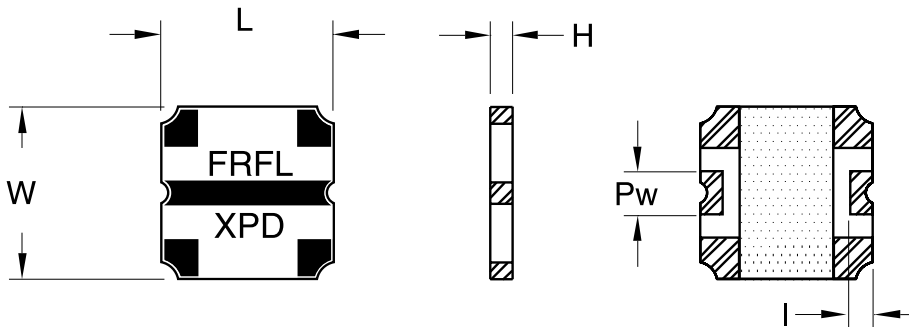

Mounting Footprint

